



Research Article

RELIABILITY ASSESSMENT OF RADIAL NETWORKS VIA MODIFIED RBD ANALYTICAL TECHNIQUE

Mohammed WADI^{1*}, Mustafa BAYSAL²

¹*Electrical Engineering Department, Istanbul Sabahattin Zaim University, ISTANBUL; ORCID:0000-0001-8928-3729*

²*Electrical Eng. Dep., Yildiz Technical University, Esenler-ISTANBUL; ORCID:0000-0002-6298-918X*

Received: 01.03.2017 Revised: 28.04.2017 Accepted: 09.05.2017

ABSTRACT

Reliability evaluation based on two basic methods namely, historical assessment and predictive assessment. In addition, predictive reliability techniques used in power system analysis can be divided into two main categories: analytical analysis and simulation analysis. In analytical techniques, the reliability indices are calculated directly from a simplified mathematical model that represent the system. Reliability Block Diagram is basically used to assess the reliability of networks contain only one source and one load. The main contribution of this paper that develops Reliability Block Diagram as an analytical technique to assess the radial networks reliability with one source and multiple loads in combinations with failure mode and effect analysis technique. To show the applicability of the proposed technique, a numerical example with three different case studies is investigated. Modified Reliability Block Diagram technique is appropriate for radial networks with multiple load points, simpler and more applicable than other analytical techniques such as Markov Analysis and Fault Tree Analysis.

Keywords: Reliability assessment, analytical techniques, reliability block diagram, failure mode and effect analysis (FMEA), modified RBD.

1. INTRODUCTION

The international standards IEC 60300-3-1 defines the main used reliability analysis methods. The most widely used analytical quantitative methods are Reliability Block Diagram (RBD), Fault Tree Analysis (FTA), and Markov Analysis (MA). However, the Monte Carlo (MC) reliability analysis is the most popular one between reliability simulation methods. Distribution networks work mainly in radial way based on one source or multiple sources that supply multiple loads. However, recently, the ring operation of distribution network has become popular to increase system reliability and to improve system availability [1]. In [2], improved RBD analysis for reliability assessment in industrial application is proposed to assess reliability of complex system but only with one source and one load. In this paper, the modified analytical technique RBD is developed to analyze the reliability of radial networks with multiple loads [2], [3], [4].

Reliability can be defined as the ability of a device to perform the function it is designed for under the operating conditions encountered during its projected lifetime [5]. In other words, it is

* Corresponding Author: e-mail: mohammed.wadi@izu.edu.tr, tel: (212) 692 88 52

the probability of equipment not failing in a specified time interval [6]. In terms of numbers, reliability is equal to the number of surviving/remaining units at specific time divided by the total/original number of units. Simply, any system reliability $R(t)$ can be calculated by equation (1). However, the probability of failure $R_f(t)$ – or the complement of reliability $Q(t)$ - can be computed by equation (2).

$$R(t) = \frac{N_r}{N_T} \tag{1}$$

where:

$R(t)$: The reliability of system

N_r : The number of remaining units

N_T : The total number of units and equal to $N_r + N_f$

$$R_f(t) = Q(t) = \frac{N_f}{N_T} \tag{2}$$

where:

$R_f(t)$: The probability of failure

$Q(t)$: The complement of reliability

N_f : The number of failure units

2. RELIABILITY BLOCK DIAGRAM

RBD is a logical representation of the system’s components in the form of blocks. Block represents one component or subsystem. In addition, RBD is considered as the basis for all later reliability evaluation techniques. The block diagram consists from combinations of series, parallel or series-parallel blocks with one input and one output. Successful operational system requires at least one continuous path between the input and output of the system [7], [8]. RBD technique is appropriate for simple and radial networks with only one source and one load point.

2.1. Serial RBD Systems

Serial systems are made up of two or more subsystems or components in series. Functionally, a series connection means that every component in the series is required to operate in order the system to success. However, system failure occurs if either one or more component fail[7]. Figure 1 shows the RBD with three series components. Assume that the probability of reliability of each component is $R_i(t)$. Then the reliability of overall serial system $R_s(t)$ with n components can be calculated by equation (3):

$$R_s(t) = R_1(t) \times R_2(t) \times R_3(t) \times \dots \times R_n(t) \tag{3}$$

However, equation (3) can be written in compact form as follow:

$$R_s(t) = \prod_{i=1}^n R_i(t) \tag{4}$$

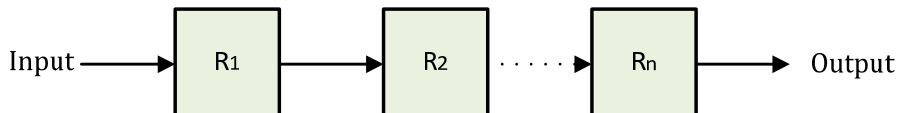

Figure 1. A serial RBD with three components

Most of the components lifetimes follow the exponential distributed probability density function. Assume the failure rate of individual components is $\lambda_i(t)$. Then the reliability of the serial system is also exponentially distributed and can be computed by equation (5) [9].

$$R_s(t) = \exp[-\sum_{i=1}^n \lambda_i t] \tag{5}$$

2.2. Parallel RBD Systems

Parallel systems are made up of two or more subsystems or components in parallel. Functionally, a parallel system requires one or more of components to success. However, system failure occurs if all components fail at the same time. Figure 2 shows the RBD with three parallel components. Table 1 explains the formulas using to calculate the failure rate, average repair time and average annual outage time for two parallel and three parallel components. Assume that the probability of reliability of each component is $R_i(t)$. Then the reliability of overall parallel system $R_p(t)$ with n components can be calculated in terms of probability of failure $Q(t)$ by equation (6).

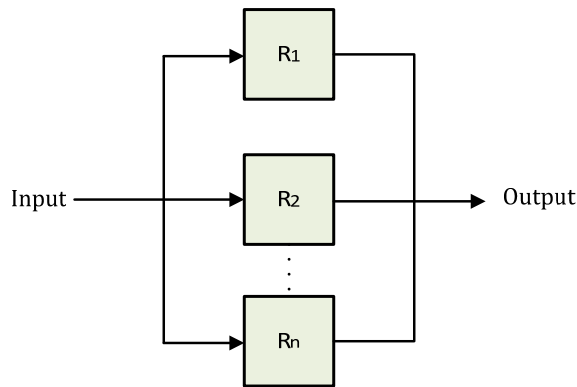

Figure 2. A parallel RBD with three components

$$R_p(t) = 1 - \prod_{i=1}^n Q_i(t) \tag{6}$$

Table 1. Load point reliability indices for parallel systems

# Parallel Component	λ [failure/year]	r [hrs.]	$U_p = \lambda_p r_p$ [hrs./year]
Two Component	$\frac{\lambda_1 \lambda_2 (r_1 + r_2)}{1 + \lambda_1 r_1 + \lambda_2 r_2}$ $\lambda_1 \lambda_2 (r_1 + r_2)$ if $\lambda_i r_i \ll 1$	$\frac{r_1 r_2}{r_1 + r_2}$	$\lambda_1 \lambda_2 r_1 r_2$
Three Component	$\lambda_1 \lambda_2 \lambda_3 (r_1 r_2 + r_2 r_3 + r_3 r_1)$	$\frac{r_1 r_2 r_3}{(r_1 r_2 + r_2 r_3 + r_3 r_1)}$	$\lambda_1 \lambda_2 \lambda_3 r_1 r_2 r_3$

Similarly, assume the components lifetimes follow the exponential distributed probability density function and the failure rate of individual components is $\lambda_i(t)$. Then the reliability of the parallel system is as follow [10]:

$$R_p(t) = 1 - \prod_{i=1}^n (1 - \exp[-\sum_{i=1}^n \lambda_i t]) \tag{7}$$

3. MODIFIED RELIABILITY BLOCK DIAGRAM TECHNIQUE IN DISTRIBUTION SYSTEMS

RBD is considered the basis for all later and modern reliability evaluation techniques. It is applicable for analysis the reliability of simple radial distribution systems with only one source and one load point. However, in this paper, modified RBD is developed to evaluate the reliability of radial system with multiple load points. The modified technique based on a combination of RBD by FMEA. Figure 3 depicts the flowchart of the proposed technique. Based on equations (5-10) and Table 1, modified RBD can be applied on network that depicted in Figure 4. It is important to execute the reliability analysis of any system, to determine the basic three load point reliability parameters, λ , r , and U respectively [1], [11].

$$\lambda_{sys} = \sum_i \lambda_i \tag{8}$$

$$U_{sys} = \sum_i \lambda_i r_i \tag{9}$$

$$r_{sys} = \frac{U_{sys}}{\lambda_{sys}} = \frac{\sum_i \lambda_i r_i}{\sum_i \lambda_i} \tag{10}$$

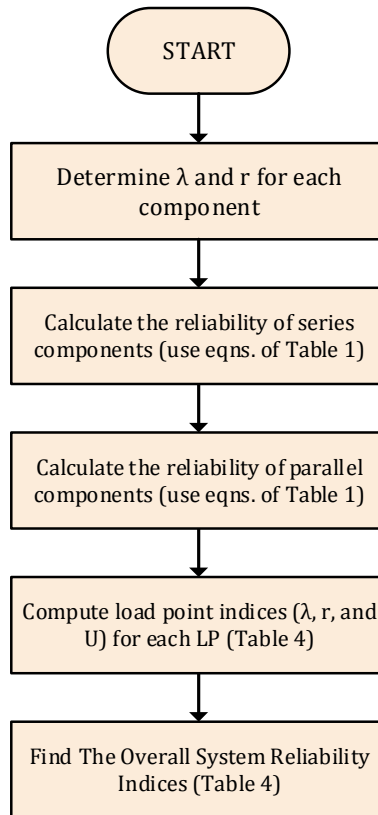

Figure 3. Modified RBD technique flowchart

$$SAIFI = \frac{\text{Total Number of Customer Interruptions}}{\text{Total Number of Customers Served}} = \frac{\sum_i \lambda_i N_i}{\sum_i N_i} \tag{11}$$

$$SAIDI = \frac{\text{Sum of Customer Interruption Durations}}{\text{Total Number of Customers Served}} = \frac{\sum_i U_i N_i}{\sum_i N_i} \tag{12}$$

$$CAIDI = \frac{\text{Sum of Customer Interruption Durations}}{\text{Total Number of Customer Interruptions}} = \frac{\sum_i U_i N_i}{\sum_i \lambda_i N_i} \tag{13}$$

$$ASAI = \frac{\text{Customer Hours of Available Service}}{\text{Customer Hours Demanded}} = \frac{\sum_i N_i \times 8760 - \sum_i U_i N_i}{\sum_i N_i \times 8760} \tag{14}$$

$$ENS = \text{Total Energy not Supplied by the System} = \sum_i L_i U_i \tag{15}$$

$$AENS = \frac{\text{Total Energy not Supplied}}{\text{Total Number of Customers Served}} = \frac{\sum_i L_i U_i}{\sum_i N_i} \tag{16}$$

where:

N_i : is the number of customers of load point i

8760: is the number of hours in a calendar year

L_i : is the average load connected to load point i

Table 2. Reliability parameters for under studied system

Component	Length [km]	λ [f/y]	r [hrs.]
Section			
1	2	0.2	4
2	1	0.1	4
3	3	0.3	4
4	2	0.2	4
Lateral			
1	1	0.2	2
2	3	0.6	2
3	2	0.4	2
4	1	0.2	2

depending on these parameters, many system indices can be computed such as [10]: The System Average Interruption Frequency Index (SAIFI), the System Average Interruption Duration Index (SAIDI), the Customer Average Interruption Duration Index (CAIDI) and the System Reliability Index or the Average System Availability Index (ASAI) as described by equations (11) -(16). Both Tables 2 and 3 summarize the required data for reliability assessment. Figure 4 shows the understudied network.

3.1. Case 1: Reliability Indices with Effect of Protection Devices Failures

Most of power utilities assuming that the protection devices are 100% ideal in operation when they study the system reliability. However, protection devices have a range of failure [12], therefore; most of utilities provide their systems with secondary protection as a back-up when the primary protection fails to clear the fault. In this case, the failure effects of fuses will be considered with assuming the probability of fuse to operate is 0.9 at each lateral branch. Therefore, failures at lateral branches 2, 3 or 4 will impact the LP1. Similarly, for load points

LP2, LP3 and LP4. The impact of failure rate can be calculated using Bayes' theorem as following [13]:

$$\text{Failure Rate} = (\text{failure rate at branch } i | \text{fuse operates}) \times P(\text{fuse operates}) + (\text{failure rate at branch } i | \text{fuse fails}) \times P(\text{fuse fails}) \quad (11)$$

For fuse 1 at the lateral branch 1:

$$\text{Failure Rate} = 0 \times 0.9 + 0.2 \times 0.1 = 0.02$$

Similarly, the failure rate at lateral branches 2, 3 and 4 is 0.06, 0.04 and 0.02 respectively.

Table 3. Customer and load connected to the under studied system

Load Point	# of Customer	Connected Load [KW]
LP1	1000	5000
LP2	800	4000
LP3	700	3000
LP4	500	2000
Total	3000	14000

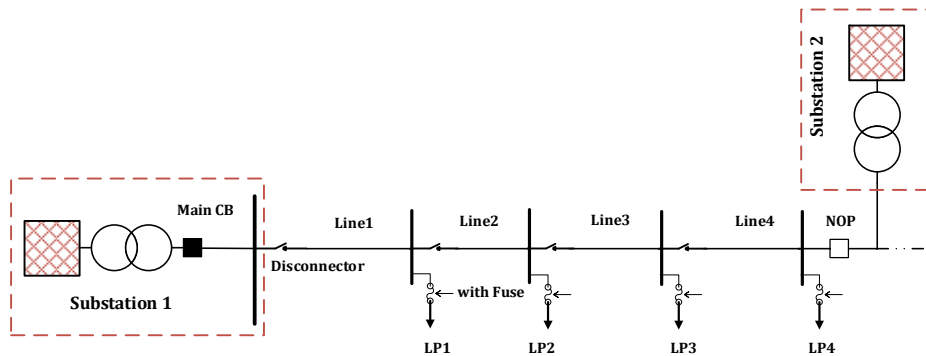

Figure 4. Under studied radial distribution network

In this case, the system reliability indices are improved as shown below:

- SAIFI = 1.258 interruptions/customer/ year
- SAIDI = 2.629 hours/customer interruptions/ year
- CAIDI = 2.089 hours/customer / year
- ASAI = 0.999699
- ENS = 35.93 MWh/year
- AENS = 11.98 kWh/year

3.2. Case 2: Reliability Indices with Transferring loads (No Restrictions on Transfer)

One of widely-used method for improving the reliability of power system is the load transferring between systems [14], [15]. This method not only used between the utilities at the same country; but it is a useful solution to enhance the reliability of power systems between countries. The mechanism of this principle is to use normally open point (NOP). When there is any fault through the main feeder, then the disconnector from the direction of substation 1 is opened and NOP is closed from the direction of substation 2.

This procedure can have a great impact on the reliability indices; because instead of leaving loads disconnected until repair it can be energized from another part of the system.

In this case, it is important to notice that the farthest load point – LP4 – from main source and nearest to NOP, dramatically impacted by load transferring.

the system reliability indices are improved as shown below:

SAIFI = 1.153 interruptions/customer/ year
 SAIDI = 1.795 hours/customer interruptions/ year
 CAIDI = 1.556 hours/customer / year
 ASAI = 0.999795
 ENS = 25.05 MWh/year
 AENS = 8.35 kWh/year

3.3. Case 3: Reliability Indices with load Transferring Restrictions

Load transferring is a beneficial principle to improve the reliability of power systems. unfortunately, it is difficult or not practical to transfer all loads through NOP. This restriction originates from many reasons, if the failure occurs through peak load periods in which all feeders are full of capacity, the feeder which is being used for load transferring has bounded capacity, or the supplying source provides the second system of network has limited capacity.

In this case, the outage time associated with failure either equal to isolation and switching time if the load can be transferred, or equal to repair time if the load cannot be transferred. Recalling to Bayes' theorem, the outage time can be calculated as following:

$$\begin{aligned} \text{Outage Time} = & \\ & (\text{outage time at section } i|\text{transfer}) \times P(\text{transfer}) + \\ & (\text{outage time at section } i|\text{no transfer}) \times P(\text{no transfer}) \end{aligned} \quad (12)$$

In this case, the probability of being able to transfer load is 60%; then

$$\begin{aligned} P(\text{transfer}) &= 0.6, \text{ and } P(\text{no transfer}) = 0.4 \\ (\text{outage time}|\text{transfer}) &= 0.5 \text{ hrs, and } (\text{outage time}|\text{no transfer}) = 4 \text{ hrs} \end{aligned}$$

As an example, the outage time of load point LP2 of Figure 4 due to failure of feeder section 1 can be evaluated as follow:

$$\text{Outage Time} = 0.5 \times 0.6 + 4 \times 0.4 = 1.9 \text{ hrs} \quad (13)$$

the system reliability indices are improved as shown below:

SAIFI = 1.153 interruptions/customer/ year
 SAIDI = 2.107 hours/customer interruptions/ year
 CAIDI = 1.827 hours/customer / year
 ASAI = 0.999759
 ENS = 29.11 MWh/year
 AENS = 9.70 kWh/year

By investigating the obtained indices in case 3, there is some expected degradations in values comparing with case 2 at which the probability of load transferring was 100%. In order to easily compare between the different cases, Table 4 and Figures 5 and 6 summarize all load point and system indices. Case 2 with main CB, sectionalizer at each line and load transfer without any restriction has the highest reliability level. Further, the proposed technique is suitable for different case reliability studies.

Table 4. Summary of cases

Component	Case 1	Case 2	Case 3
LP1			
λ (f/yr)	1.12	1.00	1.00
r (hrs)	1.39	1.50	1.50
U (hrs/yr)	1.56	1.50	1.50
LP2			
λ (f/yr)	1.48	1.40	1.40
r (hrs)	1.82	1.39	1.59
U (hrs/yr)	2.69	1.95	2.23
LP3			
λ (f/yr)	1.30	1.20	1.20
r (hrs)	2.58	1.88	2.23
U (hrs/yr)	3.35	2.25	2.67
LP4			
λ (f/yr)	1.12	1.00	1.00
r (hrs)	3.27	1.50	2.34
U (hrs/yr)	3.66	1.50	2.34
System indices			
SAFI	1.258	1.153	1.153
SIADI	2.629	1.795	2.107
CAIDI	2.089	1.556	1.827
SAI	0.999699	0.999795	0.999759
ENS	35.93	25.05	29.11
AENS	11.98	8.35	9.70

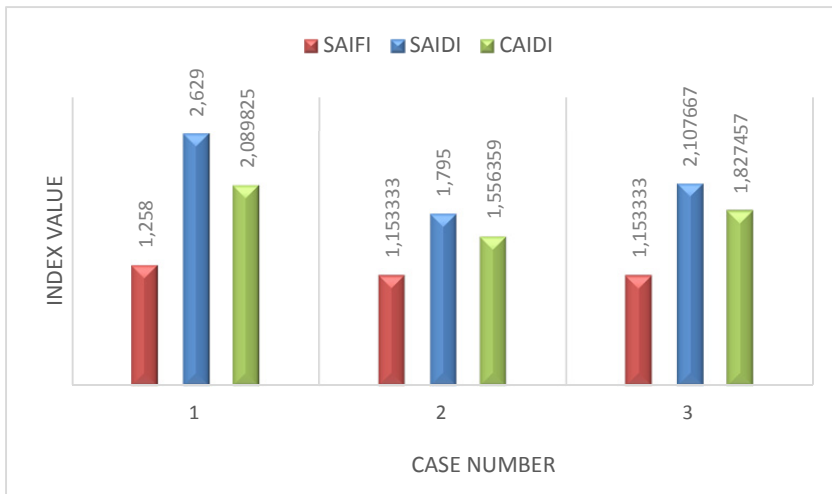

Figure 5. Comparison between cases instead of SAIFI, SAIDI and CAIDI

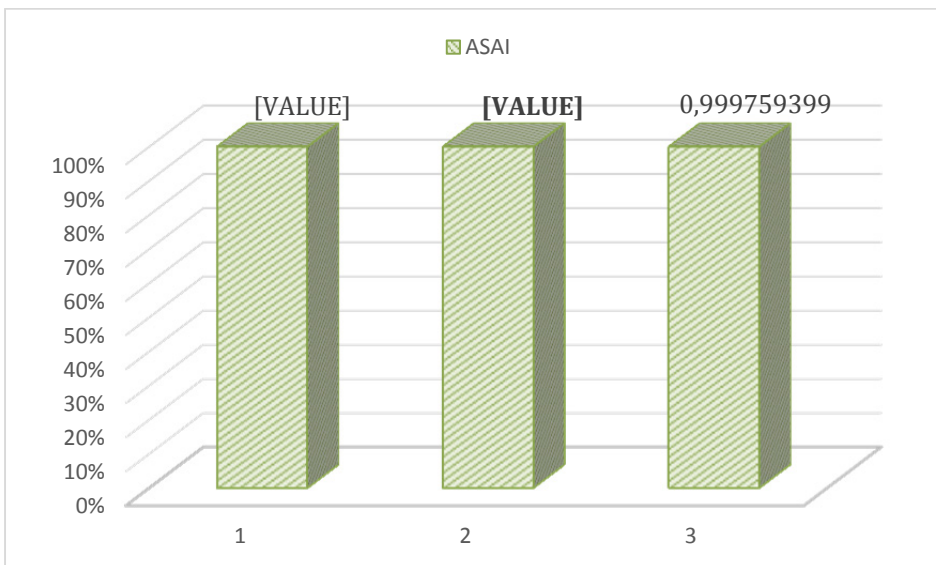

Figure 6. Comparison between cases instead of ASAI

4. CONCLUSION

In this paper, the Modified Reliability Block Diagram technique based on FMEA is developed to analyze the reliability of radial systems with multiple load points. It is an analytical technique and it's used in this article to assess four load points radial system reliability. In order to show the applicability and effectivity of the proposed technique, the reliability of radial network is investigated with numerical example and case studies. Three different case studies show how the reliability of systems can be simply evaluated and improved. It can be concluded that the

Modified Reliability Block Diagram technique is appropriate for radial networks with multiple load points, simpler and more applicable than other analytical techniques such as Markov Analysis and Fault Tree Analysis.

REFERENCES

- [1] M. Wadi, M. Baysal and A. Shobole, "Comparison between Open-Ring and Closed-Ring Grids Reliability," in 4th International Conference on Electrical and Electronics Engineering, Ankara, 2017.
- [2] M. Catelani, L. Ciani and M. Venzi, "Improved RBD analysis for reliability assessment in industrial application," in IEEE International Instrumentation and Measurement Technology Conference (I2MTC) Proceedings, Montevideo, 2014.
- [3] C. Suthapanuna, P. Jirapongb, P. Bunchoo and P. Thararak, "Reliability Assessment Tool for Radial and Loop Distribution Systems Using DIgSILENT PowerFactory," in 12th International Conference on Electrical Engineering/Electronics, Computer, Telecommunications and Information Technology (ECTI-CON), Hua Hin, 2015.
- [4] B. Canizes, J. Soares, Z. Vale and C. Lobo, "Optimal Approach for Reliability Assessment in Radial Distribution Networks," IEEE Systems Journal, vol. PP, no. 99, pp. 1-11, 2015.
- [5] O. Shavuka, K. Awodele, S. Chowdhury and S. Chowdhury, "Reliability analysis of distribution networks," in International Conference on Power System Technology (POWERCON), Hangzhou, 2010.
- [6] M. Jirgl, Z. Bardac, K. Stibor and M. Havlikova, "Reliability analysis of systems with a complex structure using Monte Carlo approach," in 12th IFAC Conference on Programmable Devices and Embedded Systems, Velke Karlovice, 2013.
- [7] M. Catelani, L. Ciani and M. Venzi, "Reliability assessment for complex systems: A new approach based on RBD models," in IEEE International Symposium on Systems Engineering (ISSE), Rome, 2015.
- [8] M. Catelani, L. Ciani and M. Venzi, "Reliability assessment for complex systems: A new approach based on RBD models," in IEEE International Symposium on Systems Engineering (ISSE), Rome, 2015.
- [9] A. Chowdhury, "Distribution system risk assessment based on historical reliability performance," in IEEE International Conference on Electro Information Technology, Lincoln, 2005.
- [10] A. A. Chowdhury and D. O. Koval, Power Distribution System Reliability, Practical Methods and Applications, Canada: John Wiley & Sons, Inc., 2009.
- [11] A. Tio and I. Cruz, "A binary formulation of SAIDI for the predictive reliability assessment of radial distribution systems with tie-lines," in IEEE PES Asia-Pacific Power and Energy Engineering Conference (APPEEC), Kowloon, 2013.
- [12] M. I. Ridwan, K. L. Yen, I. A. Musa and B. Yunus, "Reliability and availability assessment of transmission overhead line protection system using reliability block diagram," in IEEE International Conference on Power and Energy (PECon), Kuala Lumpur, 2010.
- [13] R. A. Billinton, Reliability Evaluation of Power Systems, New York: Springer US, 1996.
- [14] L. L. Eng and V. N. Min, "Special Load Shedding Scheme to Enhance System Stability of Small Power System," in International Conference on Power System Technology, Chongqing, 2006.
- [15] M. Attia, S. M. Senouci and E.-H. Aglzim, "New optimization and security approaches to enhance the Smart Grid performance and reliability," in 7th International Conference on the Network of the Future (NOF), Buzios, 2016.